



Flygt progressing-cavity grinder pump

AN INDUSTRIAL-QUALITY PUMP FOR THE DOMESTIC USER

FLYGT
a xylem brand

Small, competitive and made to last



Home-owners want an affordable, low-amperage pump that won't clog. Wastewater consultants want a pump to recommend that will last for many years.

The Flygt progressing-cavity pump has everything you require for low pressure sewer systems:

- It gives you the high head you need for low pressure sewer pumping.
- It is powered by a small, low-amperage motor that runs from any standard domestic power supply*.
- * The pump is available in both single- and three-phase versions.
- It has a robust, high-chrome steel grinding mechanism that is used in tens of thousands of municipal pump stations around the world.
- And it is a Flygt pump: a cast iron, quality product that is made to industrial specifications through and through.

A great package deal

And best of all, you can order the pump as part of an all-in-one package. That's a pump, plus a pre-fabricated basin, plus a pump controller - in one competitive package. All from a single supplier.

Functions and flexibility

The image above shows a typical low pressure sewer system where each home is equipped with its own grinder station. The network of stations connects to the force main with small diameter pipes. This makes low pressure sewer systems a cost effective alternative to septic systems.

Heads of up to 240 feet

60 Hz - 1,7 HP 230v 1-phase

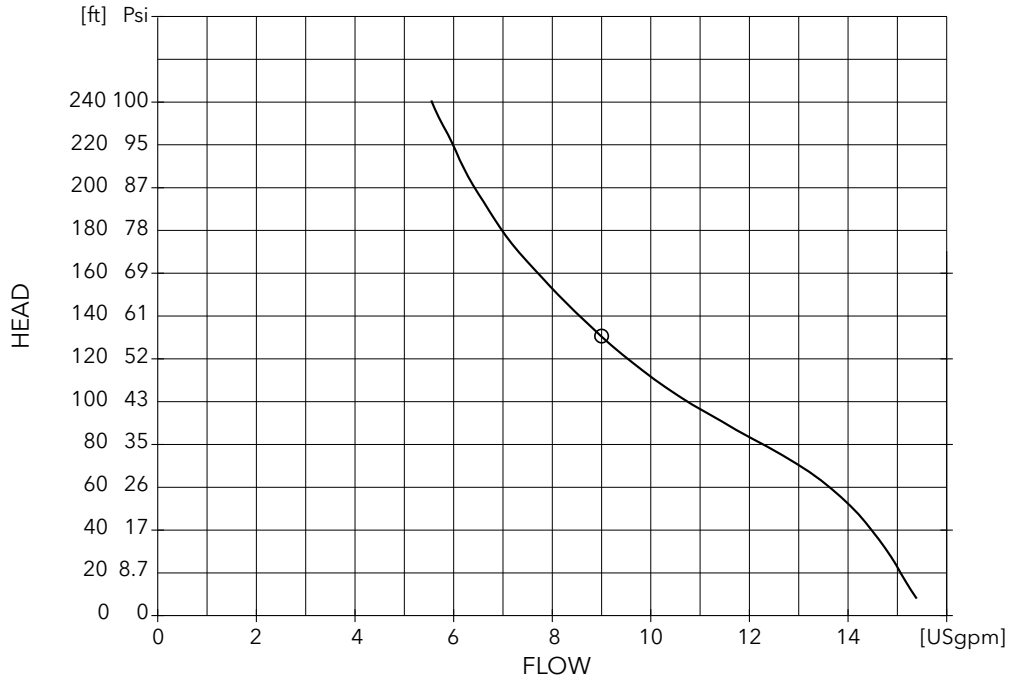

A compact pump

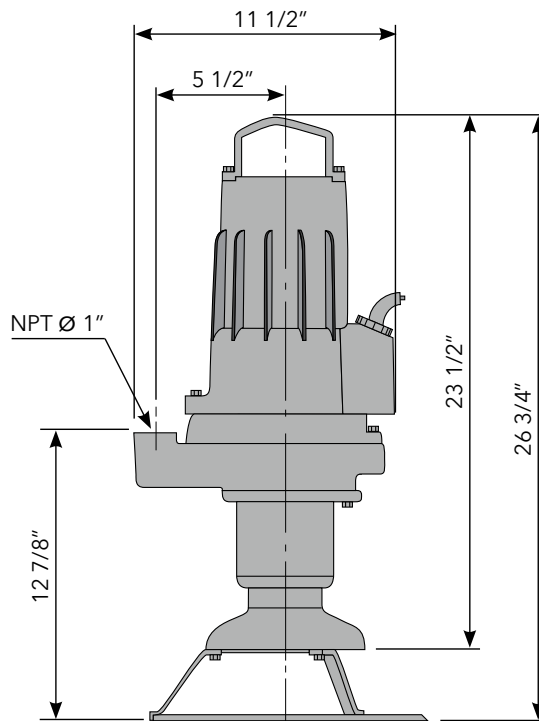

How Flygt pumps are made to last

Class-F quality motor

At Xylem, we manufacture our own motors that are made to operate in submersible pumps. Inside our progressing-cavity pump, you'll find a squirrel cage induction motor, made to Class F specifications. The stator windings are trickle impregnated with resin; this method eliminates air pockets in the windings, allowing the motor to run cooler, which extends the motor life. Our motor is rated at 310°F, allowing up to 30 starts per hour.



Low flow, high heads

A Flygt progressing-cavity pump produces a stable flow at high heads. The pumping action is produced by a corkscrew-shaped rotor that turns in a rubber stator. As the rotor turns, water trapped in cavities between the rotor and stator "progresses" through the pump.



Robust grinder

The grinding mechanism has a long and successful track-record having been used in municipal pumps for over 20 years. It is extremely robust and can handle a wide range of different solids. The grinder chops up all solid material into pieces so small that they pass through narrow pipes with ease. Made of high-chrome steel, the grinding mechanism is wear-resistant and durable.



Double seal system

Our unique dual-tandem, double-mechanical seal system protects the motor from leakage. Working independently of each other, they offer extra security and prolong intervals between services.

Well-balanced drives

Vibration is minimized thanks to a manufacturing process that produces shafts to the most exacting tolerances. A smooth running drive shaft ensures high motor efficiency and lower energy consumption. With over 100,000 units in use, the track record speaks for itself.

Long-life bearings

Reliability is further enhanced thanks to two-row, angular-contact ball-bearings. They are pre-packed with high temperature grease for maintenance-free performance.

Efficient motor cooling

The motor is heat-shrink fitted to ensure full metal-to-metal contact with the outer housing which is cooled by the surrounding liquid. Fins on the outside of the housing also dissipate heat.

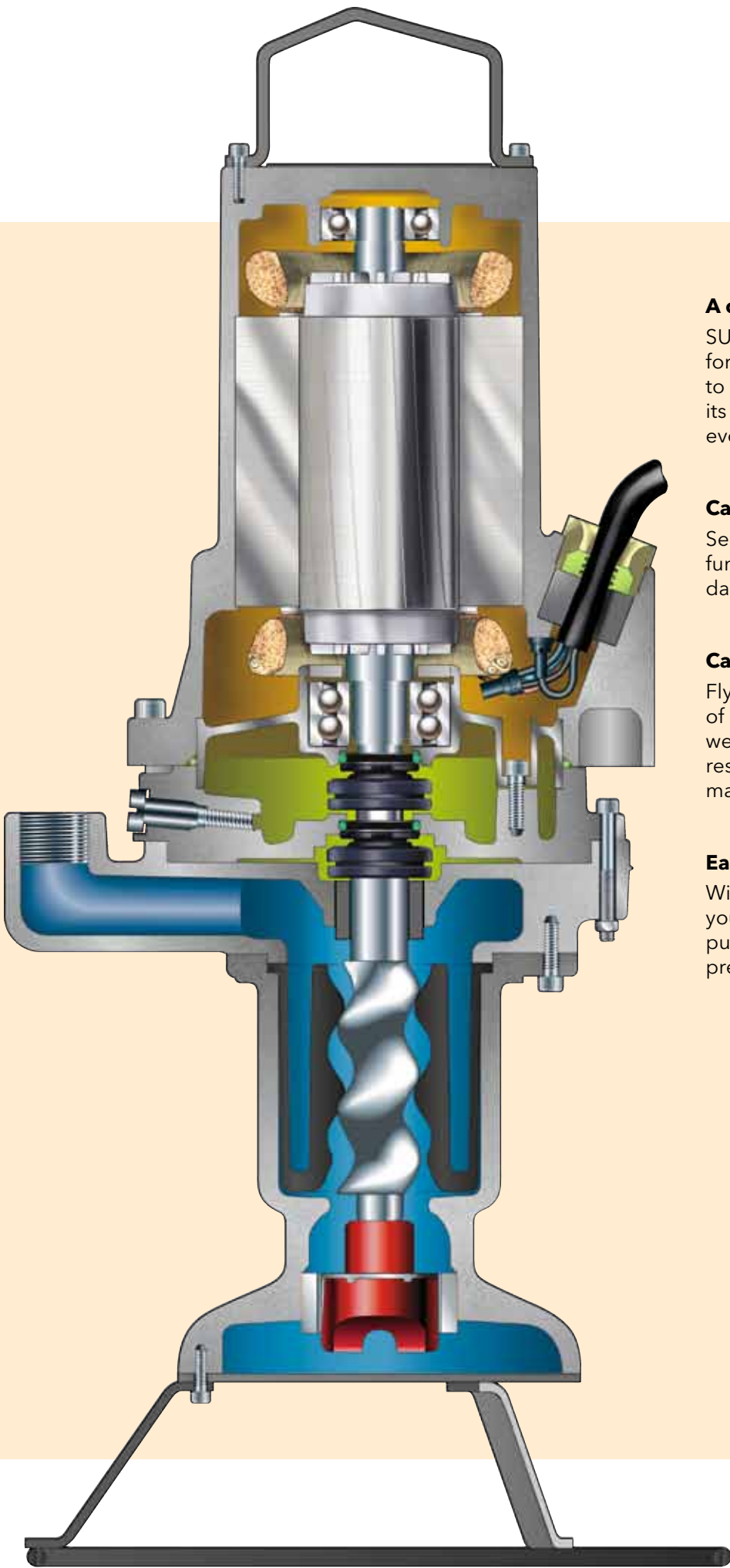

A cable made for use in water

SUBCAB has been developed by Xylem for use in submersible applications. Due to its low liquid absorption rate, it retains its mechanical and physical properties even after long periods of use.

Cable entry

Separate sealing and strain relief functions reduce the risk of cable damage from improper handling.

Cast iron reliability

Flygt progressing-cavity pumps are made of cast iron: a material that offers good wearability and corrosion resistance. The result is a robust pump that will last for many years.

Easy to install

With its standardized connections, you can use Flygt progressing-cavity pumps in existing sumps and in Xylem's prefabricated Flygt pump stations.

A competitive pump in a competitive package

To make life easier for wastewater consultants and installers, we have put together a package that contains a Flygt 3068 progressing cavity pump, prefabricated station and the FGC211 controller designed for use in low pressure sewer systems. By matching equipment designed for residential pump stations, we are able to offer this integrated package at a competitive price.

A complete pump station, ready-made

Flygt's LPSS prefabricated pump station for low pressure sewer systems comes complete ready for immediate installation and connection to the home.

Flexible design

The Flygt Advanced LPSS residential stations are available in simplex or duplex configurations. Simplex stations are available in 24 and 30" diameter, while duplex are 48" diameter. Both simplex and duplex stations are available in depths from 6 to 16 feet. The inlet can be field installed to match the needs of each job site.



Alternative solution with a pressure bell.

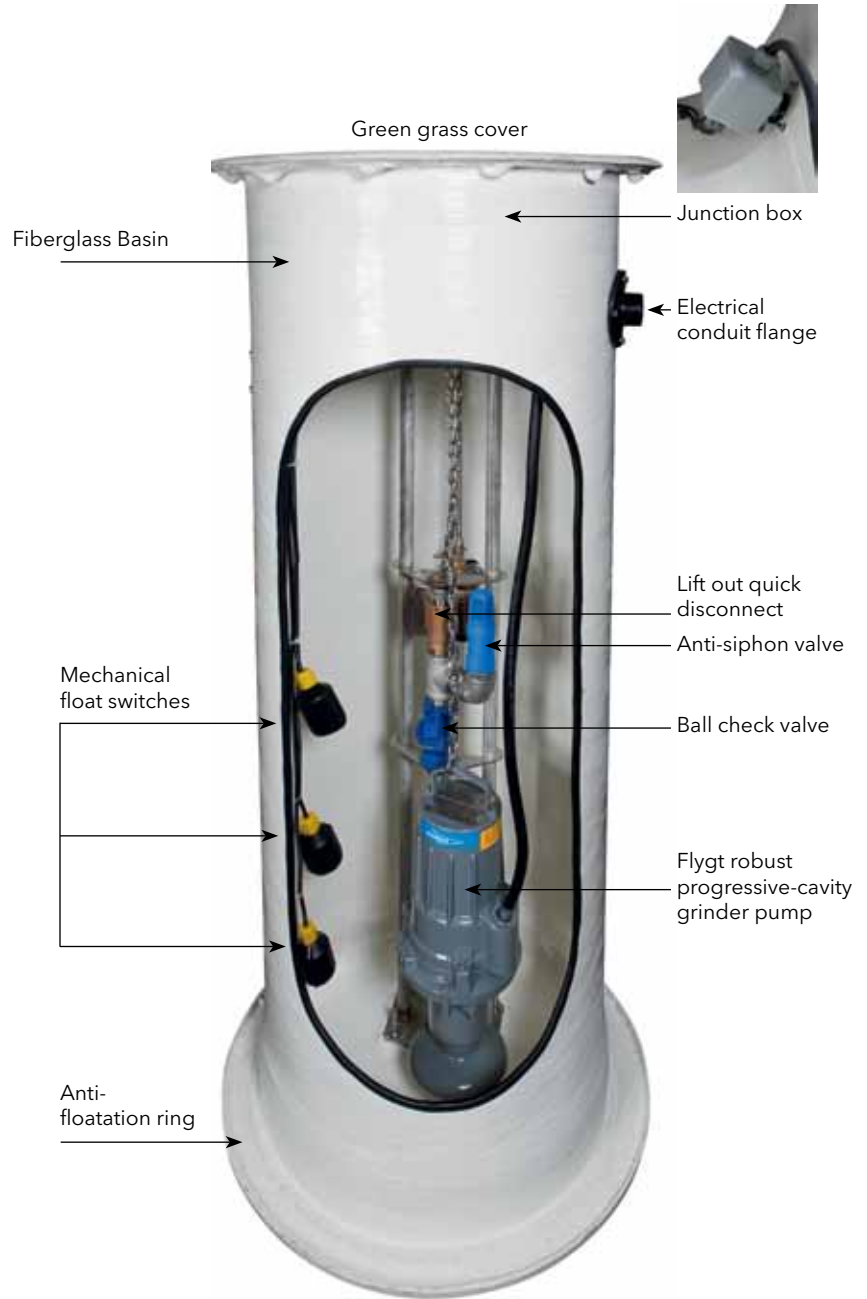

Reduce Running and Service Costs

The Flygt FGC211 is a compact and robust, simplex pump controller for pumps up to 10 amps that you can modify and accessorize according to your pump station's specific needs. The affordably priced FGC controller is perfect for low pressure sewer systems. Features such as display and outdoor cabinet exemplifies our dedication to meeting user needs.

FGC211 LPSS Control Features

Motor Protection

Built in overload protection and user defined maximum motor current.

Pump Starting and Stopping Sequences

Menus to specify the pump operating sequences pump, for example timed runs.

Maintenance Runs

Exercises for 1 second every 4 days to keep seals adequately lubricated.

Manual/Auto Control Blocking

Automatically/manually blocked pump operation in the event of a pump fault.

Automatic Reset

The FGC allows the end-user to enter the number of automatic restarts from 1-200. The counter clears after a successful restart.

Backup Control

A backup function intervenes to start the pump when receiving a high level alarm.

Starting and Power on Delay

To prevent an over-pressure situation, the FGC starts pumps with a delay of 1-120 seconds when starting the pumps after a power interruption.



The pump maker that knows its systems

Designing a low pressure sewer system is simple in theory, but harder in practice. Having been in the pump business for over 60 years, we have learned a thing or two about pump systems. Today, we have a team of system engineers who have the knowledge to provide qualified design recommendations and solutions. They know their theory and have had plenty of practice in the field.

Xylem |'zīləm|

- 1) The tissue in plants that brings water upward from the roots;
- 2) a leading global water technology company.

We're 12,000 people unified in a common purpose: creating innovative solutions to meet our world's water needs. Developing new technologies that will improve the way water is used, conserved, and re-used in the future is central to our work. We move, treat, analyze, and return water to the environment, and we help people use water efficiently, in their homes, buildings, factories and farms. In more than 150 countries, we have strong, long-standing relationships with customers who know us for our powerful combination of leading product brands and applications expertise, backed by a legacy of innovation.

For more information on how Xylem can help you, go to www.xyleminc.com



Xylem, Inc.
14125 South Bridge Circle
Charlotte, NC 28273
Tel 704.409.9700
Fax 704.295.9080
www.xyleminc.com

Flygt is a trademark of Xylem Inc. or one of its subsidiaries.
© 2012 Xylem, Inc. FEB 2012